

超级电容器
产品规格书

Electrical Double Layer Capacitor
Data Sheet

客户 Customer: _____
产品 Product: 144V62F
型号 Code: SMD1440R62R5CAFZF01
日期 Date: 2023/03/14



公司地址: 中国·重庆市九龙坡区凤笙路 21 号金凤园区新材料产业园 4 号楼
Add: 21 Fengsheng Road, Bld.4, Novel Material Branch of Jinfeng Electronic Information Industrial park,
Hi-tech Industrial Development Zone, Chongqing, China
联系电话(Tel): +86-023-65935981
网址(Website): www.zkcrtech.com

工艺	品管	审核	客户核准

1、 适用范围 Scope

此规格书对产品的性能，测试方法进行了规范，作为技术确认的依据。

As a basis for technical confirmation, this sheet specifies the performance and test methods of the product .

2、 产品特性 Features

- ★High energy density 比能量大
- ★High power density 高功率
- ★Long cycle life 寿命长
- ★Safe and reliable 安全可靠
- ★Environment-friendly 环境友好
- ★Maintenance-free 免维护
- ★Charge-discharge speed at the scale of second 充放电速度可达秒级

3、 应用领域 Applications

/

4、 命名规则 Designation

表1 命名规则

SMD 1440 R 62R5 CA F Z H0 1

模组分类 Module classification	额定电压 (V) Rated Voltage	容量偏差(%) Tolerance	额定容量(F) Rated Capacitance	引出方式 Structure	包装 Packaging	制造商 Manufacture	模组PCB状态及版本信息 Module PCB status and version	模组版本信息 Module version
双电层 电容器模组	144V	0~+20%	62.5F	连接片引出	金属外壳	中科超容	主动耗能式均衡, 带单体电压采集、温度监测和通讯等功能 (第1版)	第1版 (高功率)

5、 标准测试条件 Test Conditions

环境温度 Ambient temperature: 15°C ~ 35°C

湿度 Humidity: 25%RH ~ 75%RH

气压 Pressure: 86kPa~106kPa

*电容量、内阻和漏电流尤其受温度的影响很大，如对结果有疑问，应按以下条件进行测量：

The capacitance, internal resistance and leakage current are particularly affected by temperature. If in doubt about results, make measurements under the following conditions:

环境温度 Ambient temperature: 20°C±2°C

湿度 Humidity: 63%RH ~ 67%RH

气压 Pressure: 86kPa~106kPa

6、性能参数 Parameters

表2 模组性能参数表

电气性能 Electrical Performance		
容量 Capacitance	额定容量, Rated Capacitance, F	62.5
	容量偏差, Capacitance Tolerance, %	0% ~ +20%
电压 Voltage	额定电压, Rated Voltage, V.DC	144
	浪涌电压, Surge Voltage, V.DC	148
内阻 Internal Resistance	DC/m Ω@25°C (测试时间0.1s)	≤6
	DC/ mΩ@25°C (测试时间1s)	≤6.8
电流 Current	72 小时泄漏电流, 72-hour Leakage Current, mA	< 6@144V
	最大持续电流Maximum Continuous Current (ΔT=15°C), A	130
	1s 最大峰值电流, 1s Maximum peak Current, A	2500
质量 Mass	典型质量, Typical mass, kg	≤40
能量 Energy	最大存储能量, Maximum stored Energy, Wh	180
	能量密度, Energy Density, Wh/kg	4.5
功率密度 Power Density	功率密度, Power Density, kW/kg	10.4
温度 Temperature		
温度区间 Temperature Range	工作温度范围, Temperature for Operation, °C	-40 ~ +65
	存储温度范围, Temperature for Storage, °C	-40 ~ +70
寿命 Life		
使用期限 Life Time	额定电压下工作 10 年 After 10 years at rated voltage(25°C)	
	容量变化 (初始值衰减) Capacitance change (decrease from initial value)	≤ 20%
	内阻变化 (初始值增大) Internal Resistance (increase from initial value)	≤ 2 倍 (times)
耐久性 Endurance	额定电压下工作 1000 小时 After 1000 hours at rated voltage (65°C)	
	容量变化 (初始值衰减) Capacitance change (decrease from initial value)	≤ 20%
	内阻变化 (初始值增大) Internal Resistance (increase from initial value)	≤ 2倍 (times)
保存期限 Shelf Life	4 年 (25°C, 未充电) 4 years (25°C, uncharged)	
循环寿命 Cycle Life	25°C恒定电流, 额定电压到 1/2 额定电压之间循环 50 万次 Constant current at 25 °C, 500,000 cycles between rated and 1/2 rated voltages	

	容量变化 (初始值衰减) Capacitance Change (decrease from initial value)	≤ 20%
	内阻变化 (初始值增大) Internal Resistance (increase from initial value)	≤ 2 倍 (times)

7、外形尺寸(单位: mm) Dimensions (Units : mm)

7.1 Dimensions 外形尺寸(Units 单位: mm)



图1 模组尺寸图

表3 模组尺寸表

长度 (mm) Length	宽度 (mm) Width	高度 (mm) Height	备注 Remark
581	430	156	

7.2 Signal Connector 信号接口器

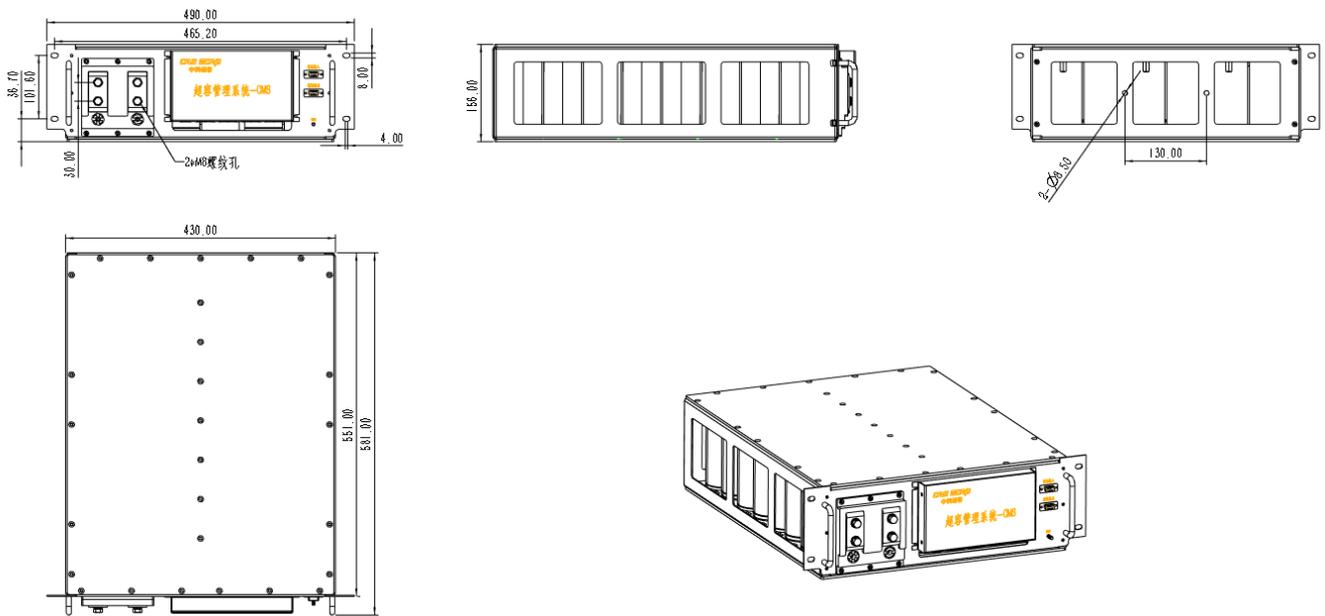
7.2.1 Interface Definition 接口定义

表4 模组引脚接口定义

主电源接口	引脚定义	功能
"+"号标识	主电源正极	2*M8螺纹孔
"-"号标识	主电源负极	2*M8螺纹孔
GND	外壳接地连接点	外壳接地
通讯输入——插座DB9		

Number 端子编号	Function 端子功能	Remark备注
1	NC	
2	CAN-L	
3	GND	电源负
4	NC	
5	NC	
6	NC	
7	CAN-H	
8	NC	
9	24V+	电源正
通讯输出——插座DB9		
1	NC	
2	CAN-L	
3	GND	电源负
4	NC	
5	NC	
6	NC	
7	CAN-H	
8	NC	
9	24V+	电源正

通讯输入

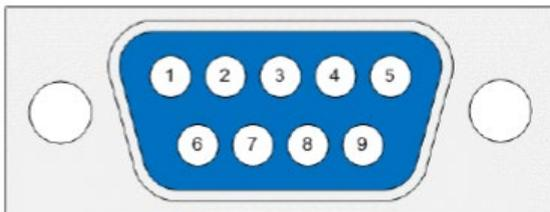

通讯输出



图2 模组通讯输出连接器示意图

8、 产品测试方法 Testing method

8.1 额定容量 (六步法, F)和直流内阻(六步法, Ω)/ Rated Capacitance (six-step, F) and DC internal resistance (six-step, Ω) :

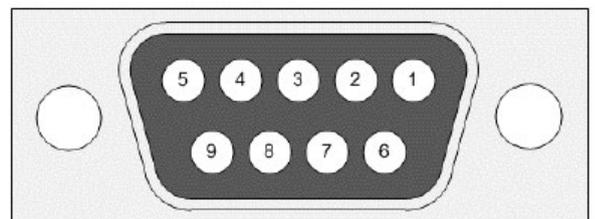

图3 六步法测试示意图

表5 六步法测试步骤表

No.	Items项目	condition条件	Remark备注
1	搁置10s Put on hold 10S		V_0
2	恒流充电 I_1 Constant current I_1 charging	以 I_1 恒流充电至额定电压 U_R Charge to rated voltage U_R at constant current I_1	I_1 、 V_1
3	搁置5s Put on hold 5S		
4	搁置10s Put on hold 10S		V_3 、 t_4
5	恒流放电 I_2 Constant current I_2 discharging	以 I_2 恒流放电至50% U_R Discharge at constant current I_2 to 50% U_R	I_2 、 V_4 、 t_5
6	搁置5s Put on hold 5S		V_5 、 t_6
7	重复步骤1-6, 重复1次 Repeat steps 1-6 once		T_{10} 、 t_{11} 、 V_9 、 V_{10} 、 V_{11}
8	结束 End	以 I_2 恒流放电至0.1V以下 Discharge at constant current I_2 to 0.1V	

参数计算 Parameter calculation:

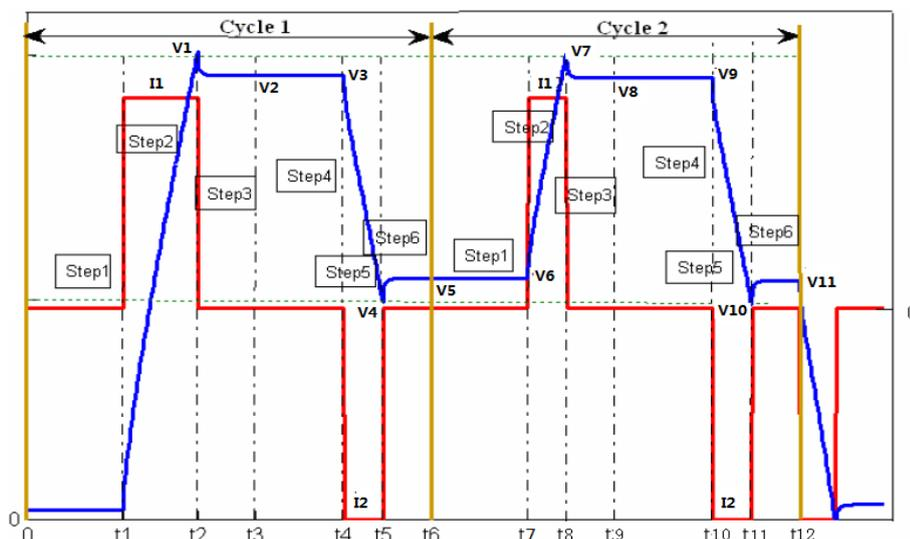
- 两次循环放电容量 Two-cycle discharge capacity :

$$Cd_{ch1} = I_2 \times \frac{t_5 - t_4}{V_3 - V_4}$$

$$Cd_{ch2} = I_2 \times \frac{t_{11} - t_{10}}{V_9 - V_{10}}$$

- 放电容量 Discharge capacity :

$$Cd_{ch} = \frac{Cd_{ch1} + Cd_{ch2}}{2}$$

- 两次循环放电直流内阻 Two-cycle discharge DC internal resistance :

$$ESR_{dch1} = \frac{V_5 - V_4}{I_2};$$

$$ESR_{dch2} = \frac{V_{11} - V_{10}}{I_2}$$

- 直流放电内阻 DC discharge resistance :

$$ESR_{dch} = \frac{ESR_{dch1} + ESR_{dch2}}{2}$$

*其中: $I_1 = I_2 = 100A$, 参数表中, 直流内阻 ESR_{DC} 指六步法直流放电内阻。

Among them: $I_1 = I_2 = 100A$, in the parameter table, the DC internal resistance refers to the six-step DC discharge internal resistance.

8.2 交流内阻 AC ESR (Ω)

测量电路: Measurement circuit:



图4 交流内阻测试示意图

内阻计算公式: ESR calculation: $R_{AC} = \frac{U}{I}$

U: 交流电压有效值, AC voltage rms, (V r.m.s)

I: 交流电流有效值, AC current rms, (A r.m.s)

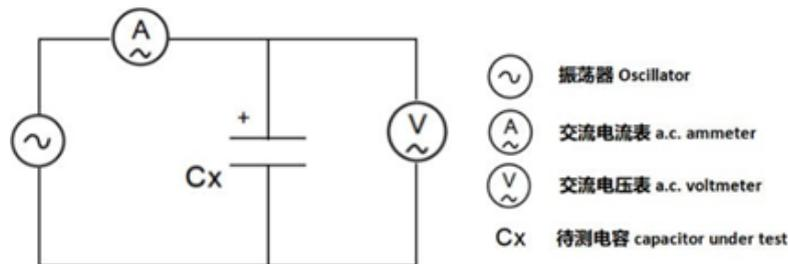
测量电压的频率, Measurement frequency of the voltage should be : 1 kHz;

交流电流应为, The AC current should be : 1mA ~ 10mA

8.3 最大持续电流 Maximum Continuous Current :

最大持续工作电流 ($\Delta T = 15^\circ C$) : Maximum continuous working current within 15 °C

of temperature change (A) : $I_{CC} = \sqrt{\frac{\Delta T}{ESR_{DC} * R_{th}}}$

8.4 最大峰值电流 Maximum Peak Current :

一秒钟放电至一半额定电压的最大放电电流 (A) : Maximum current needed to

discharged from rated voltage to half rated voltage in 1 second (A) : $I_{max} = \frac{\frac{1}{2}U_R}{ESR_{DC} + \frac{1}{C}}$

8.5 能量与功率 Energy and Power:

最大储存能量 Maximum stored energy (Wh) : $E_{max} = \frac{\frac{1}{2} \times C \times U_R^2}{3600}$

能量密度 Specific Energy (Wh/kg) : $E_d = \frac{\frac{1}{2} \times C \times U_R^2}{3600 \times mass}$

功率密度 Usable Specific Power (kW/kg) : $P_d = \frac{0.12 \times U_R^2}{ESR_{DC} \times \text{mass}}$

9、 注意事项 Cautions

下述注意事项需严格遵守。对于没有按照以下注意事项所造成的任何意外事故，**重庆中科超容科技有限公司**不承担任何责任。

The warnings should be followed seriously, otherwise **Chongqing CAS Supercap Technology Co., Ltd.** is not responsible for any loss caused by misconduct.



注意事项

- 超级电容器应在额定电压和规定工作温度区间使用，不宜超过65°C，并远离超过工作温度区间的热源；
- 超级电容器在使用前需确认正/负极，禁止反向充电。若正负极接反，会降低超级电容器的充放电性能，并会导致发热、泄露和使用寿命快速衰减。
- 超级电容器在使用前用干布对正/负极端子进行清洁，避免接触电阻过大降低超级电容使用性能。
- 禁止将超级电容器投入火中或进行高压加热。
- 禁止将超级电容直接与水、油、酸或碱接触。
- 禁止挤压、钉刺和拆解超级电容器。
- 禁止将带有 0.5V 以上电压的超级电容器进行正/负极短接；
- 在使用或储存期间如发现超级电容器有散发气味、变色、变形或其它反常之处应停止使用。
- 超级电容器所使用的电解液极易挥发，请不要随意分解超级电容器。
- 超级电容器不能随意丢弃，需请根据国家环保标准进行处理。



Cautions

- The capacitor should be used in the rated voltage and specified operating temperature range with no more than 65 °C, and stay away from heat sources that exceed the operating temperature range;
- The positive/negative electrodes of the capacitor must be confirmed before use, and reverse charging is prohibited. The reverse connection will reduce the performances of the capacitor and cause heat cause heat generation, leakage and rapid deterioration of service life;
- Clean the positive/negative terminals with a dry cloth before use to avoid excessive contact resistance, which would degrade the performances of the capacitor;
- Do not put the capacitor into fire or heat it under high pressure;

- Do not contact directly the capacitor with water, oil, acid or alkali ;
- Do not squeeze, prick and disassemble the capacitor;
- Do not short-circuit the positive/negative electrodes of the capacitor with voltages above 0.5V;
- Stop using the capacitor if it is found to emit odor, discoloration, deformation or other abnormalities during use or storage;
- Do not disassemble the capacitor at will because the electrolyte is volatile;
- Do not discard the capacitor at will, Please dispose of it according to national environmental protection standards.

如有任何关于超级电容器的问题，请与我们联系。

Please contact with us if you have any question on our products.